

PSL

Pocket Strand Layering System

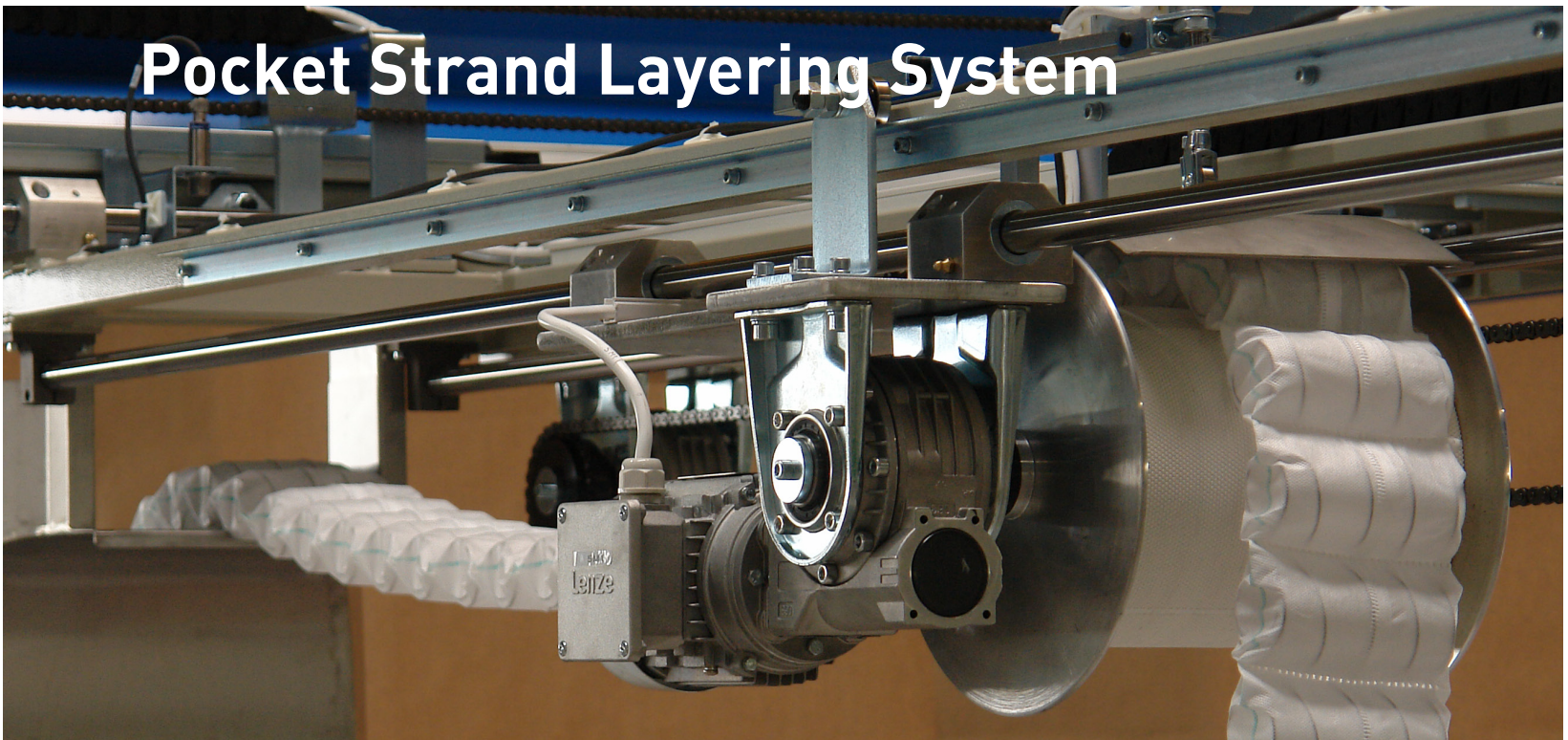

The Leggett & Platt PSL System accepts pocket spring strands directly from a coil machine and neatly layers them into a specific area/container.

Electronic sensors and switches automatically guide the machine, as it moves on an X-Y axis, throughout the layering cycles until the containing space is full. The system may be free-standing or mounted to the ceiling to better utilise space.



Please contact our sales team at:

Spühl AG | Grüntalstrasse 23 | 9300 Wittenbach | Switzerland
+41 71 292 13 12 | saleswfm@spuhl.ch | www.spuhl.ch

General Specifications:

- Maximum Coil Height – 225 mm
- Packet Material – All
- Maximum Layering Speed – 16 m / minute
- Nominal Layering Speed – 10 m / minute
- Installed Power – 0.8 kw
- Power Supply – 400 v, 3 phase, 50hz
- Approximate Machine Weight:
 - 370 kg excluding support legs
 - 510 kg including support legs

Leggett & Platt[®]
Machine Products Croatia

LPT d.o.o | Hrupine 4 | 40 323 Prelog | Croatia
+385 40 650 500 | www.leggett.com

Leggett & Platt is a diversified manufacturer (and member of the S&P 500) that conceives, designs and produces a broad variety of engineering components and products for the bedding industry and other market sectors worldwide.

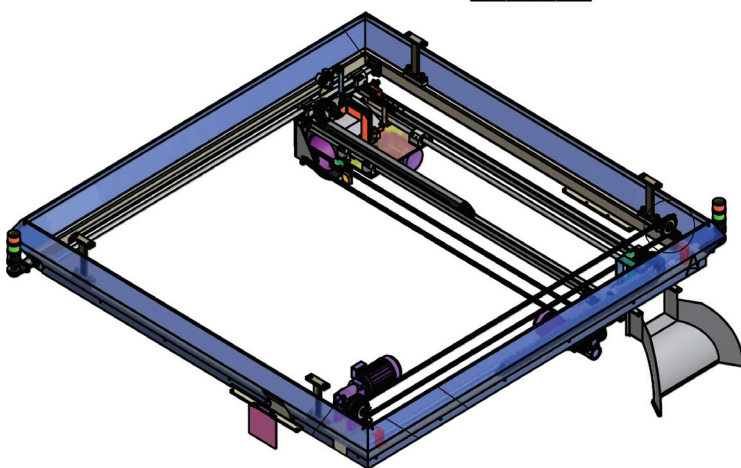
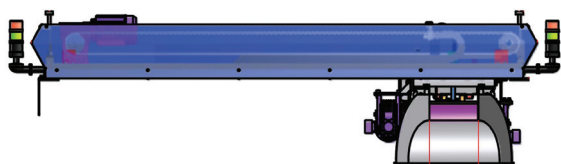

MACHINE DIMENSIONS: APPROX 2.78 X 2.95 M (HEIGHT - 0.76 M WITHOUT TROLLEY)

Available Options:

Self-standing – supplied with legs.

Roof suspended – attached to the facility ceiling.

Device will arrive with pre-assembled attaching points for roof suspension system. Roof suspension system is not included with the device; customer is solely responsible for installation and certification of the carrying mechanism.

Pocket strand trolleys – 2 x 2 x 2.4 (high) m
Approximate capacity 4000 coils (based on
70 mm dia. x 160 mm coils)

Leggett & Platt[®]
Machine Products Croatia

LPT d.o.o | Hrupine 4 | 40 323 Prelog | Croatia
+385 40 650 500 | www.leggett.com

LP_4/13 | © 2013 Leggett & Platt, Incorporated